

Dimensions

EFF Series

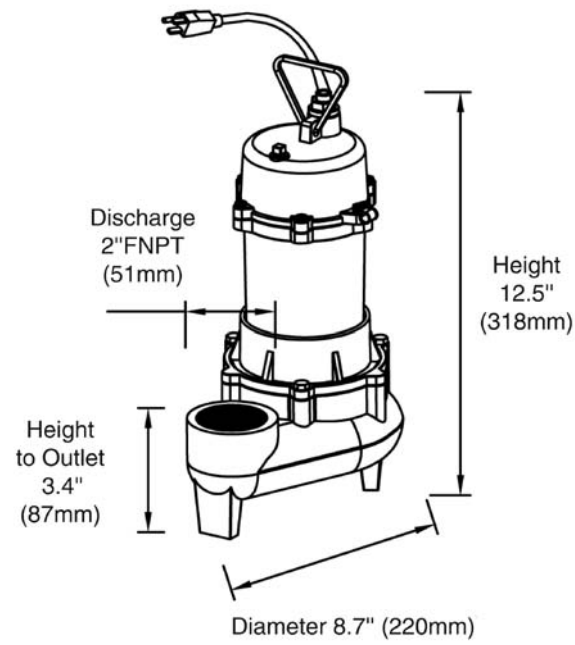

SEW Series

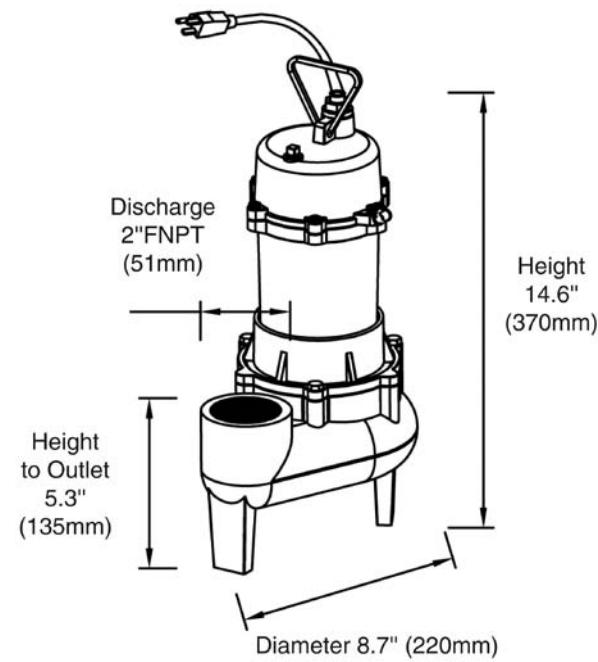

Sewage & Effluent Specifications



Sewage and Effluent Pump Specifications

Item #	Model Number	Description	TDH (ft/ m)	* Max Flow (usgpm/lps)	Solids Handling	HP	Voltage	Frequency Hz	Rated Amp	Output Power (W)	Motor Speed	Weight (lb/ kg)
45020001	EFF50	Effluent Pump	28/8.5	62/3.9	3/4"	1/2 HP	115	60	5.0	370	3500	19.8 / 9.0
45020002	SEW50	Sewage Pump	17/5.2	83/5.2	2"	1/2 HP	115	60	6.0	370	3500	22.0 / 10

* Note: Maximum flow based on a minimum 6' Head

Sewage Ejector Packages (Pump and Basin Shipped as separate Items)

45020003		1/2 HP Sewage Package c/w 18.5" x 30" (35 US gal) basin	17/5.2	83/5.2	2"	1/2 HP	115	60	6.0	370	3500	42.8 / 19.4
45020004		1/2 HP Sewage Package c/w 24" x 24" (42 US gal) basin	17/5.2	83/5.2	2"	1/2 HP	115	60	6.0	370	3500	46.8 / 21.2
45020005		1/2 HP Sewage Package c/w 22" x 33" (53 US gal) basin	17/5.2	83/5.2	2"	1/2 HP	115	60	6.0	370	3500	48.8 / 22.1

Sewage Basin Only

45070003		18.5" x 30" (35 US gal) sewage basin										18 / 8.16
45070001		24" x 24" (42 US gal) sewage basin										22 / 9.98
45070004		22" x 33" (53 US gal) sewage basin										24 / 10.89

Item #	Model Number	Description	TDH (ft/ m)	* Max Flow (usgpm/lps)	Solids Handling	HP	Voltage	Frequency Hz	Rated Amp	Output Power (W)	Motor Speed	Weight (lb/ kg)
45020006		*Pre-Assembled* 1/2 HP Sewage Package c/w 24" x 24" (42 US gal) basin	17/5.2	83/5.2	2"	1/2 HP	115	60	6.0	370	3500	46.8 / 21.2



Canature USA Inc. (Golden Valley, MN);
Canature North America Inc.
(Regina, SK; Kitchener, ON)

Your Dynamic Pump Dealer:

80152001 09/10



Professional Series Wastewater Pump



Engineered For Performance

Engineered For Performance



Engineered for Performance

The Dynamic Professional Series Sewage and Effluent pumps provide reliability and performance you can count on – all backed by a solid **Two Year Guarantee**. Designed for pumping septic tank effluent, heavy duty sump applications or 2" solids handling in domestic sewage applications for farm, home or cottage - Dynamic pumps give many years of trouble free service.



Sewage & Effluent Pumps

SEW Series

½ HP – 2" Solids

EFF Series

½ HP -3/4" Solids

2 Year Guarantee



Features:

- Cast Iron Volute and Motor Housing ensure pump longevity
- Efficient and reliable ½ hp, 115 volt / 60 hz permanent split capacitor motor provides high starting torque
- Oil-filled motor housing provides permanent lubrication of the upper and lower heavy-duty motor bearings for longer motor life
- Built in Thermal Overload protection.
- Thermoplastic vortex impeller provides low maintenance performance and superior solids handling capabilities
- Carbon/Ceramic mechanical and lip seal for added motor protection
- 20 foot power cord makes for easy "plug in" installation to any standard 115 volt power outlet
- 20 foot "Piggy-back" style float switch makes for easy trouble shooting
- Stainless Steel Lift ring offers easy installation and pump removal
- Exterior hardware and lift ring made from stainless steel for added corrosion resistance
- 2 Year Guarantee
- Maximum operating temperature 50°C

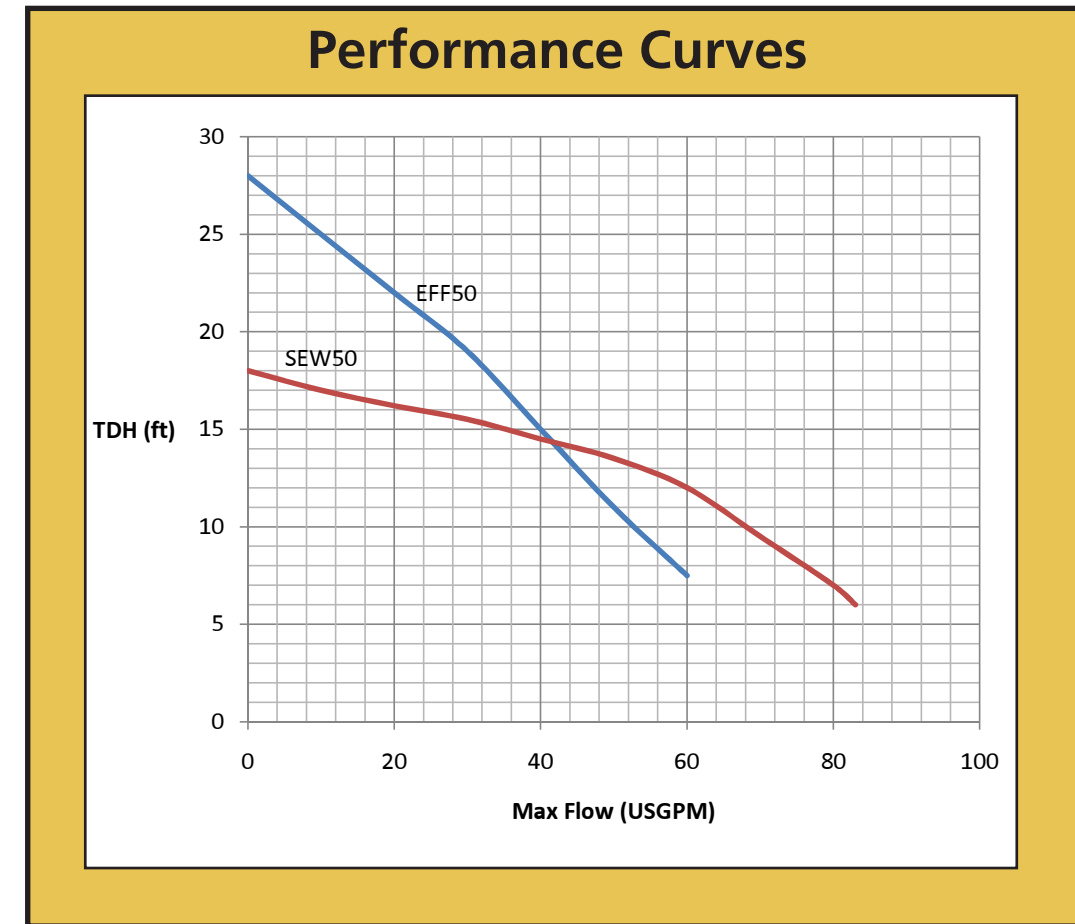

Sewage Ejector Package:

- ½ hp – 2" solids handling sewage pump
- 24" x 24" (42 Gal.) polyethylene tank with cover provide superior design and reliability as well as ease of installation.
- 4" inlet, 2" discharge connection, 2" vent connection
- Power cord grommet included



Refer to item #4501006 on back cover

Note: Pre-Packaged Sewage Ejector Packages Now Available.



45070003
18.5" diameter x 30" high
(35 Gal)



45070001
24" diameter x 24" high
(42 Gal)



45070004
22" diameter x 33" high
(53 Gal)

*Tanks may not be exactly as shown.