

89DF Single Media Tank Filter Manual

- Taste and Odor (TO)
- Neutralizer (NU)
- Birm (BM)
- Greensand (IF/GS/ISF)
- NextSand (NEX)

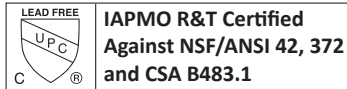
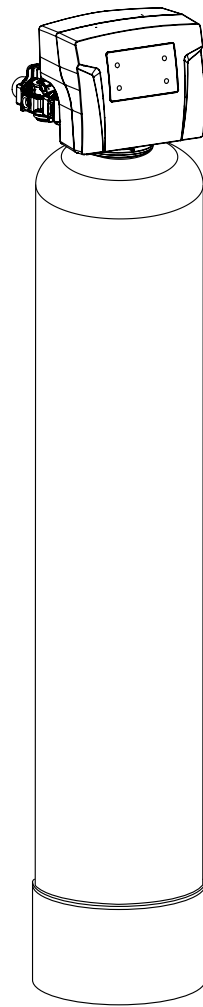

1. This manual contains important safety and operating instructions. Read all instructions and follow them when using this product. Failure to consider this information and follow these instructions, including those concerning maintenance, may result in property damage, injury and or death.

Page 21 of this manual contains important maintenance procedures for the continued proper operation of your unit. These MUST be performed regularly for your warranty to remain valid.

2. We recommend installation only be completed by a competent installer or plumbing professional to insure this product is installed in accordance with local plumbing codes.
3. Read this manual in full and follow all instructions carefully before operation.
4. Avoid pinched O-rings during installation by applying NSF certified lubricant to all seals (provided with install kit).
5. This system is not intended for treating water that is microbiologically unsafe or of unknown quality without adequate disinfection before or after the system.
6. Discard small parts remaining after the installation.
7. Failure to install the system correctly voids the warranty.
8. Handle all components of the system with care. Do not drop, drag or turn components upside down.
9. Save these instructions and keep track of your product's serial number.

NOTICE: THIS MANUAL CONTAINS A LIMITED WARRANTY. BY INSTALLING AND OR USING THIS PRODUCT, YOU WAIVE CERTAIN LEGAL RIGHTS INCLUDING THE RIGHT TO SUE OR CLAIM COMPENSATION IN THE EVENT OF PROPERTY DAMAGE, INJURY, AND OR DEATH.

Canature WaterGroup Canada Inc.
855 Park St., Unit 1
Regina, SK, S4N 6M1
Toll Free: (877) 288-9888









Canature WaterGroup U.S.A. Inc.
6353 Commerce Drive
Whitestown, IN, 46075
Toll Free: (877) 288-9888

Table of Contents

SAFETY	3
FIND AND RECORD VALVE TYPE & SERIAL NUMBERS	4
RECORDS & CONTACTS	4
KNOW THIS BEFORE STARTING YOUR INSTALLATION	5
HOW YOUR WATER FILTER WORKS	6
FEATURES & TERMINOLOGY	6
FLOW RATE INFORMATION	7
FEED WATER PARAMETERS	7
UNPACKING/INSPECTION	8
BEFORE INSTALLATION	9
PREPARATIONS	10
PLANNING YOUR INSTALLATION	12
INSTALLATION STEPS	14
GREENSAND STARTUP	16
UNDERSTAND THE SCREEN & KEYPAD CONFIGURATION	17
START-UP INSTRUCTIONS	18
OTHER MAIN MENU FEATURES	20
PLUMBING SYSTEM CLEAN UP	21
MAINTENANCE INSTRUCTIONS	21
DETERMINE THE FREQUENCY OF REGENERATION OF GREENSAND FILTERS	23
SERVICING YOUR CONTROL VALVE	24
TROUBLESHOOTING GUIDE	25
COMMON SPARE PARTS	26
WARRANTY	28

SAFETY

Throughout this manual, certain conventions are used, including;

HAZARD SYMBOLS	
	For your own safety, please pay strict attention! Examples include: temperature, electrical, and water pressure, etc.
HAZARD SIGNALS	
	Indicates a hazardous situation that, if not avoided will result in death or serious injury, and/or property loss or damage.
	Indicates a hazardous situation that, if not avoided may result in death or serious injury, and/or property loss or damage.
	Indicates a hazardous situation that, if not avoided, could result in a minor or moderate injury, and/or property loss or damage
	Indicates important information, that if not followed may result in damage to equipment, or property loss.
WARRANTY EXCLUSIONS	
	Identify specific instructions that, if not followed, will void the warranty. The warranty provided gives you specific legal rights and otherwise limits your legal rights to the extent permitted by law. By installing and/or using this product, you are accepting these limits on your legal rights.
NOTES	
	Help you take full advantage of the system and are used to emphasize installation, operation, or maintenance information that is important but does not present a hazard.
MANDATORY SIGNS	
	Used to depict a specific behavior that MUST be followed to avoid the present hazard (problem).

Canature WaterGroup U.S.A. Inc. / Canature WaterGroup Canada Inc. (“Canature”) has disclosed all known risks associated with the product within this manual but cannot disclose risks that are beyond its knowledge.

Original instructions. All information, illustrations, and specifications in this manual are based on the latest information available at the time of the publication.

The right is reserved to make changes at any time without notice.

FIND AND RECORD VALVE TYPE & SERIAL NUMBERS

There are two labels located on your Unit: **1) Control valve label** and **2) System number label**. Find and record your product model number, serial number, and valve serial number in the **Records & Contacts** section as they will be important if you need to troubleshoot.



Control Valve Serial # _____

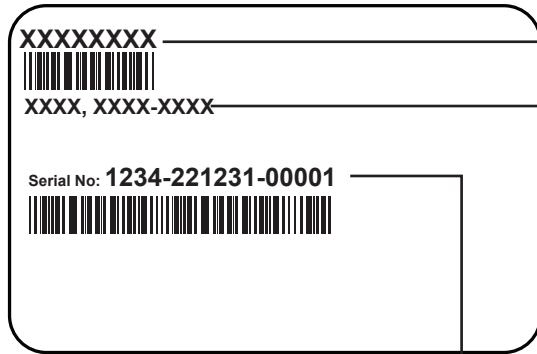

Item # _____

Model # _____

System Serial # _____

NOTE

For cabinet models, the model number and the system serial number are located under the salt lid.



NOTE

Do NOT remove or destroy the serial number. It MUST be referenced on request for warranty repair or replacement.

RECORDS & CONTACTS

Please have the information below filled out and available when calling in for parts or warranty:

YOUR DEALER:

Name: _____

Address: _____

Phone: _____

Other: _____

YOUR SYSTEM:

Model number: _____

Serial number: _____

Valve Serial number: _____

Date installed: _____

Installed by: _____

NOTES: _____

KNOW THIS BEFORE STARTING YOUR INSTALLATION

- ▶ Read this manual thoroughly to become familiar with the filter and its capabilities before installing or operating.



Failure to follow instructions could result in personal injury, property damage or death.

This manual will assist you in getting the most out of your new filter.

- ▶ The installation of this filter **MUST** be in accordance with all electrical and plumbing authorities, as well as all applicable local codes and ordinances.

Check with your local public works department for plumbing and sanitation codes.

In the event that the codes conflict with any content in this manual – the local codes should be followed.

Installation by a licensed plumber or certified water treatment professional is recommended.



- ▶ This filter is designed to operate on pressures of 30 -125 psi.

If the water pressure is higher than 125 psi, use a pressure reducing valve ahead of this filter.

- ▶ It is not uncommon for sediment, precipitated iron, or hardness to be present in water supplies.

Precipitated minerals or sediment can cause damage to the seals and piston.



If precipitated minerals or sediment are present in your water supply this will be considered a harsh environment. The seals and piston would not be covered by warranty, stated or otherwise.



- ▶ Do NOT use water that is microbiologically unsafe without adequate disinfection before or after this system.

- ▶ This filter is capable of operating at temperatures between 4 °C – 43 °C or (40 °F -110 °F).



Do NOT expose filter to freezing temperatures or vacuum.

Discharge lines exposed to freezing temperatures should be positioned with a downward slope.



- ▶ Potassium permanganate is a Class C - Oxidizing Material, Class E - Corrosive Material

- ▶ Do NOT expose filter to direct sunlight.



- ▶ Do not use this filter on hot water supply lines.

- ▶ Avoid pinched O-rings during installation by applying the silicone-based lubricant supplied. Part #92360.

- ▶ It is recommended to inspect and service the control valve on an annual basis.

Cleaning and or replacement of piston, seals, and or spacers may be necessary depending on the raw water quality.

Your installer can provide a maintenance kit for this purpose.

- ▶ Rural applications should have a water analysis annually prior to system checkup or repair.



- ▶ Chlorine bleach and common iron control chemicals may generate toxic fumes when mixed.



- ▶ Always wear appropriate safety gear, such as safety glasses.

NOTICE

The warranty provided gives you specific legal rights and otherwise limits your legal rights to the extent permitted by law. By installing and/or using this product, you are accepting these limits on your legal rights. Canature is NOT responsible for losses, injury, or death resulting from a failure to observe these safety precautions, or misuse or abuse of the equipment.

NOTE

Check with your local public works department for applicable local plumbing and sanitation codes. Follow local codes if they differ from the standards used in this manual. Otherwise, carefully follow the instructions in this manual. Canature is not liable for any non-compliance with local requirements

HOW YOUR WATER FILTER WORKS

Taste & Odor Filters (TO/TOK models)

Chlorine and organic matter can make your water smell and taste bad. The taste & odor filter uses high-quality granular activated carbon to adsorb the problem-causing substances. Chlorine is corrosive and can cause pin hole leaks in pipes.

Chloramine Removal Filters (TOC/TOCK models)

Chloramines are now commonly used to disinfect municipal water supplies causing taste & odor problems. Chlorine and chloramines are also corrosive and can cause pin hole leaks in pipes. To remove chloramines a special catalytically enhanced carbon is required.

Neutralizing Filters (NU models)

Neutralizing filters raise the pH of acidic water to neutralize corrosiveness protecting fixtures, pipes and appliances.

Iron & Sulfur Filters (IF/GS/ISF/BM models)

Water comes in contact with manganese greensand causing oxidization into solids which can be trapped in the filter bed.

NextSand Turbidity Filters (NEX models)

Remove suspended solids, ferric hydroxide (red water iron) or sediment from your well or water system down to 5 Microns.

FEATURES & TERMINOLOGY

Diagnostics

By pressing any button to light the LCD display, the unit will automatically begin scrolling important information for diagnostic purposes.

Total Gallons

The total amount of treated water the system can produce between regenerations.

Regen Time

Time of day that the filter is scheduled to regenerate.

Last Regeneration

The date of the last regeneration cycle.

Total Regeneration

The total number of times the filter has regenerated.

Historical Total Gallons

Total gallons treated by the filter.

Current Flow Rate

It will only display if treated water is running, otherwise, it will read zero (0).

System Bypass

All systems come with a manual bypass valve which allows you to bypass the 85UF/DF. This allows raw untreated water to be used in your home for any reason, including system servicing.

Manual Regen Delay

Generally, used after servicing the valve so that it will regenerate at a standard pre-set time.

FLOW RATE INFORMATION

At the stated service flow rates, the pressure drop through these devices will not exceed 15 psig.

Peak flow rates are intended for intermittent use only (10 minutes or less) and are for residential applications only. Do not use peak flow rate for commercial applications or for a continuous rate when treated water supplies are geothermal heat pump, swimming pool, etc.

For satisfactory operation, the pumping rate of the well system must equal or exceed indicated backwash flow rate.

FEED WATER PARAMETERS

Taste and Odor, Chloramines, NexSand

Maximum Iron = 0.0 ppm ferrous (clear water iron)

Maximum Hydrogen Sulfide = 0.0 ppm

Maximum Manganese = 0.0 ppm ferrous (clear water)

pH = 6.5 to 7.5

Neutralizer

Maximum Iron = 0.0 ppm ferrous (clear water iron)

Maximum Hydrogen Sulfide = 0.0 ppm

Maximum Manganese = 0.0 ppm ferrous (clear water)

pH = 6.5 to 6.9

Greensand

Maximum Load factor of 10

Iron x 1

Hydrogen Sulfide x 2

Maximum Manganese x 3

pH = 7.0 - 8.0

(Iron mg/l _____ X 1) + (manganese mg/l _____ X 2) + (Hydrogen Sulphide mg/l _____ X 3) = Total Iron mg/l _____

Birm

Maximum Iron = 10.0 ppm clear water iron or ferric iron

Maximum Hydrogen Sulfide = 0.0 ppm

Maximum Manganese = 0.0 ppm ferrous (clear water)

pH = 7.0 - 8.0

UNPACKING / INSPECTION

Be sure to check the entire unit for any shipping damage or parts loss. Also note damage to the shipping cartons. Contact the transportation company for all damage and loss claims. The manufacturer is not responsible for damages in transit.

Small parts, needed to install the filter, are in a parts box. To avoid loss of the small parts, keep them in the parts bag until you are ready to use them.

What is included in the box?

For Models 75,100,150 and 200 (TO and Birm Filter Only) you will expect the following.

Shipping Carton Quantity – 1:

1. Control Valve
2. Tank
3. Parts Box
4. Owners Manual
5. Drain Hose & Clamp (Not included in some brands)

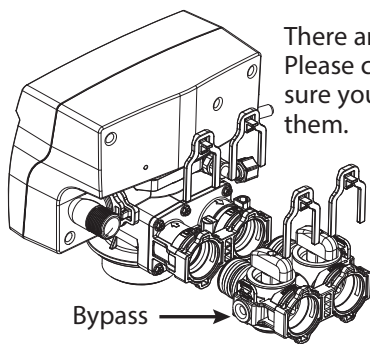
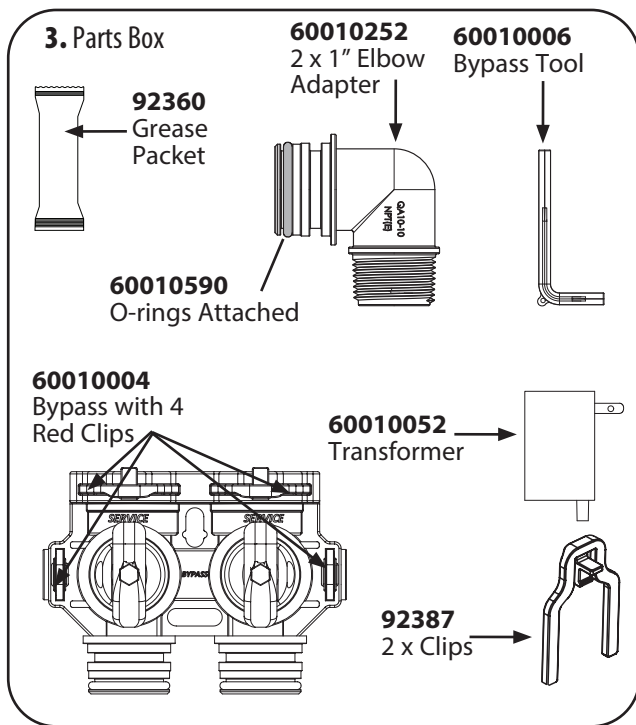

There are 7 Red clips. Please check to make sure you have all of them.

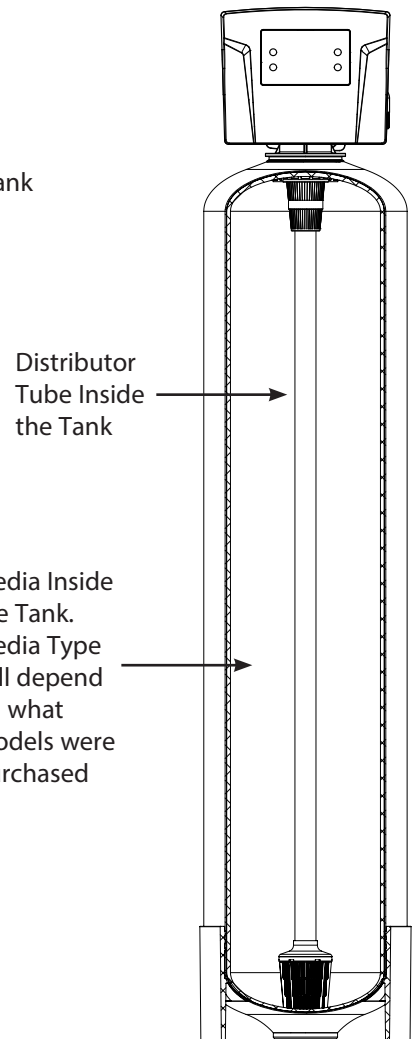
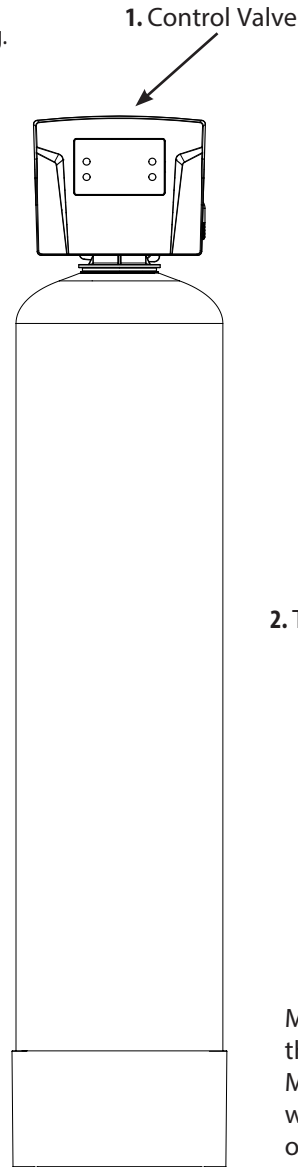

BEFORE INSTALLATION

Make sure you have a copy of your most recent water test results. If your water has not been tested previously, your professional installer can obtain a water sample bottle to be sent to one of our facilities for a free analysis. **It is important that this product not be installed until you have this information.**

In all cases where metal pipe was originally used and is later interrupted by poly pipe, or the Noryl bypass valve, an approved ground clamp with physical separation and no less than #6 copper conductor must be used for continuity, to maintain proper metallic pipe bonding.

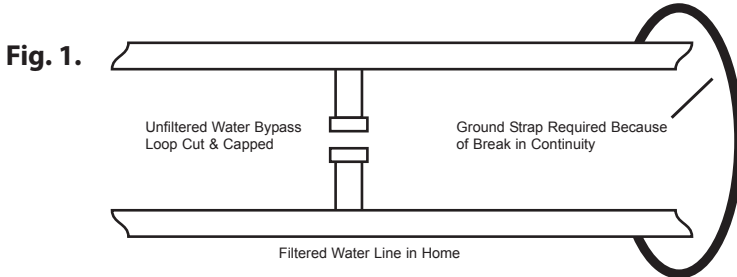

WARNING

If the ground from the electrical panel or breaker box to the water meter or underground copper pipe is tied to the copper water lines and these lines are cut during installation of the bypass valve and/or poly pipe, an approved grounding strap must be used between the two lines that have been cut in order to maintain continuity. The length of the grounding strap will depend upon the number of units being installed and/or the amount of copper pipe being replaced with plastic pipe.

See Figure 1.

MECHANICAL

Do NOT use petroleum-based lubricants such as petroleum jelly, oils or hydrocarbon based lubricants. Use only 100% silicone lubricants (packet Part #92360 provided in parts kit). All plastic connections should be hand tightened only. Thread tape may be used on connections that do not use an O-ring seal.

Do NOT use pliers or pipe wrenches except when indicated by nut shape, e.g., pipe adapters. All plumbing must be completed according to local codes. Soldering connections should be done before connecting any plastic pieces to the pipe as excessive heat can damage them.

TOOLS REQUIRED FOR INSTALLATION

- ▶ Two adjustable wrenches.
- ▶ Additional tools may be required if modification to home plumbing is required.
- ▶ Plastic inlet and outlet fittings are included with the filter. To maintain full valve flow, use of 3/4" or 1" [1.9 cm or 2.54 cm] pipes to and from the filter. You should maintain the same or larger pipe size as the water supply pipe to the filter inlet and outlet.
- ▶ Use copper, brass, or PEX pipes and fittings.
- ▶ Some codes may also allow PVC plastic pipe.
- ▶ 5/8" [15.8 mm] Outside Diameter drain line is needed for the valve drain.
- ▶ Drain line tubing may be needed for the optional brine tank overflow fitting.

NOTE

Use of a competent installer or plumbing professional to ensure this product is installed in accordance with local plumbing codes is recommended. Canature is not liable for any non-compliance with local requirements.

PREPARATIONS

MEDIA INSTALLATION (WHEN NECESSARY)

When larger units cannot be loaded due to weight restrictions, media will be shipped pre-measured in separate containers. Follow the steps below for proper media loading.

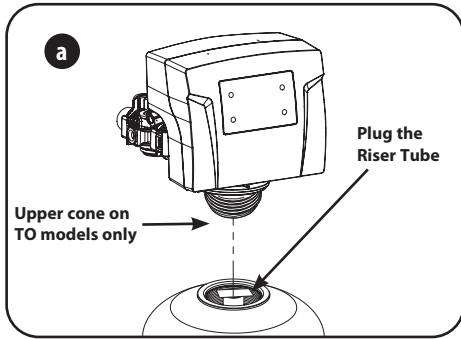

- a)** Remove the valve from the mineral tank. Add bottom cone only in TO Models

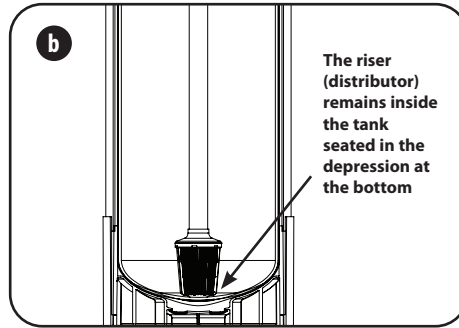

- b)** Temporarily plug the open end of the riser tube to ensure that no resin or gravel falls down into the distribution. The riser (distributor) remains inside the tank seated in the depression at the bottom.
- Plug tube with a tape. Remove after media is loaded.

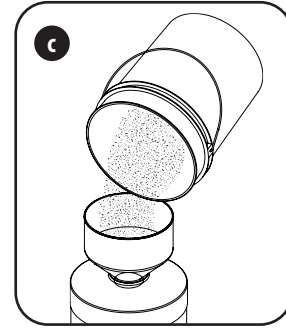

- c)** Fill support bed first. The media will not always spill down inside the tank and may need to be swept inside.
- The large funnel (sold separately makes filling the tank easier and neater. (Or an empty 1 gallon or 4 liter container with the bottom cut out makes a good funnel.)

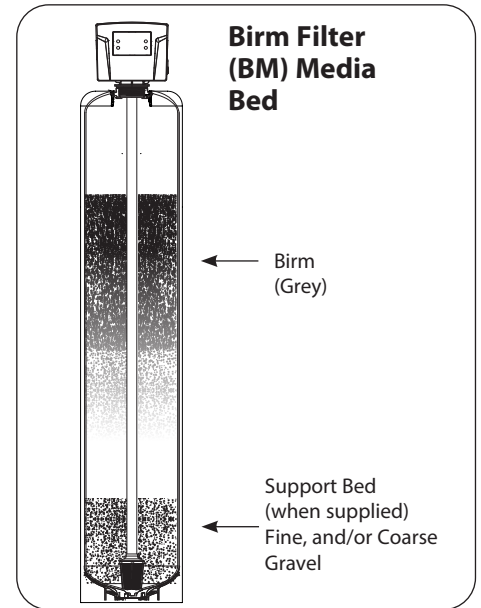
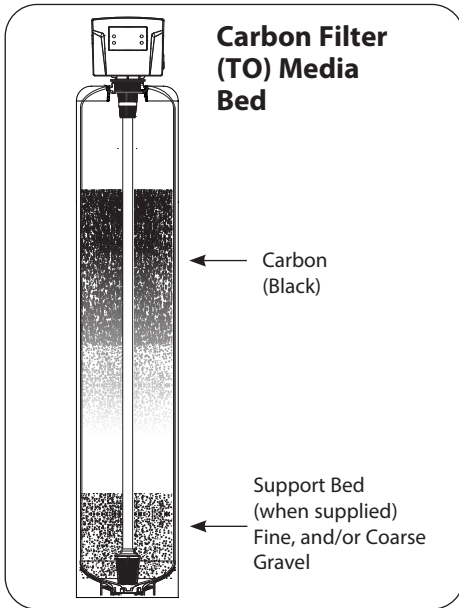
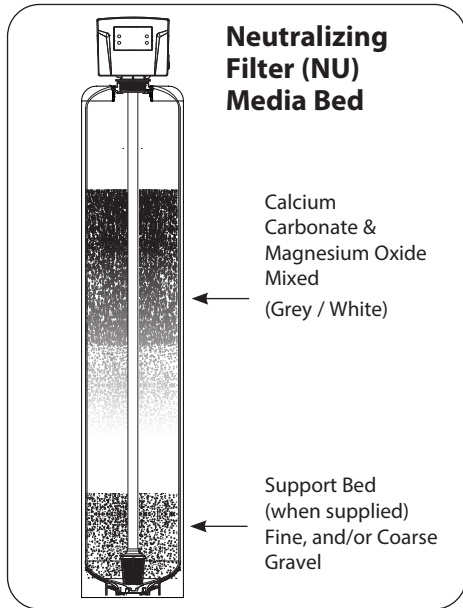

- d)** Fill tank one quarter full of water to protect distribution during gravel installation.

Place the media into the tank in the order indicated above. Slowly and carefully add the gravel support bed and the filtration media leveling each layer as it is placed into the tank.

PREPARATIONS (CONTINUED)

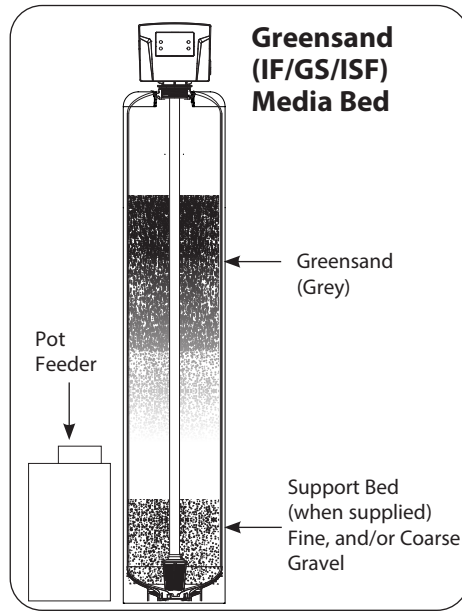
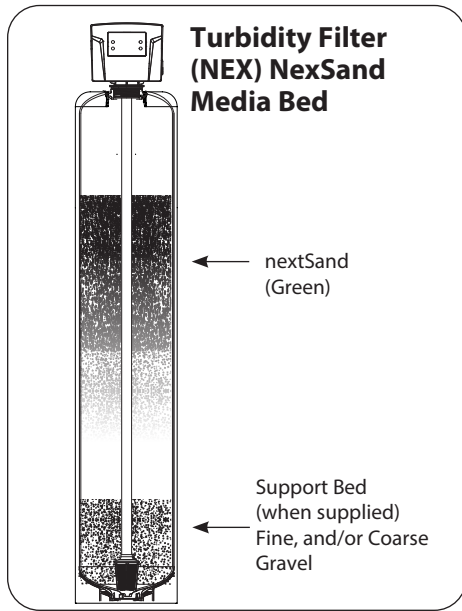

4. Apply the supplied lubricant (part #92360) to the internal O-ring at the bottom of the control valve. Apply lubricant to the larger O-ring on the bottom of the valve that seals with the tank threads.

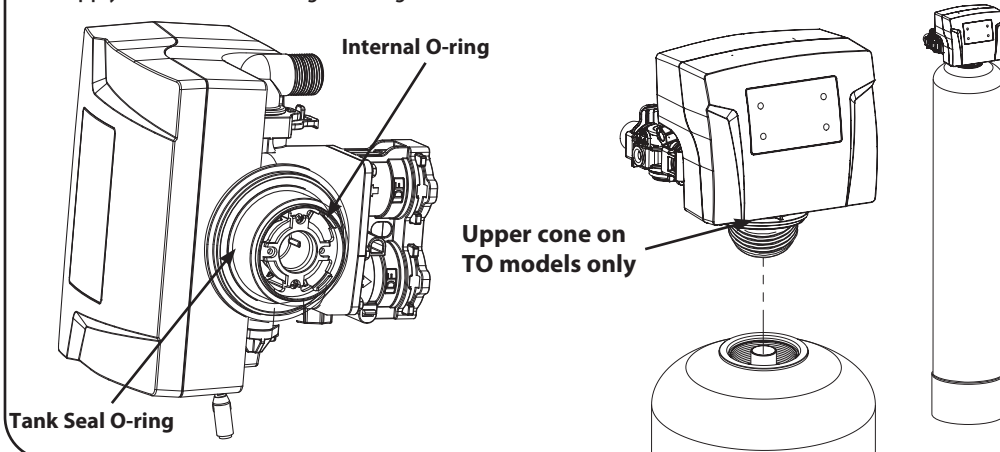

NOTICE

Do NOT use petroleum-based lubricants as they will cause swelling of the O-ring seals.

5. Remove the tape from the top of the riser tube. Carefully position the valve over the riser tube, inserting riser into the internal O-ring. Turn the valve clockwise into the threads of the tank until secure.

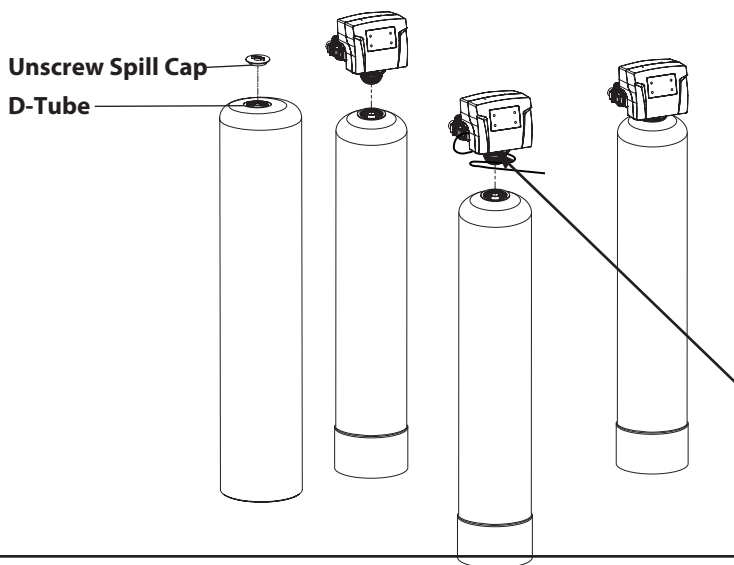

NOTICE

Make sure the quick connect power cord is not yet connected to prevent the cord getting caught between the threads of the tank and the valve.

PLANNING YOUR INSTALLATION

WATER FILTER INSTALLATION LAYOUT

Select the location for your filter tank with care. Various conditions that contribute to proper location include:

1. All installation procedures must conform to local or regional plumbing codes. Canature is not liable for any non-compliance with local requirements
2. Outside taps used to water lawns and gardens should be isolated from the water line required to supply untreated water to the inlet of the water filter – a separate (new) line may be needed.
3. Where required by local plumbing codes, a check valve may need to be installed. Canature is not liable for any non-compliance with local requirements
4. Locate filter as close as possible to the water supply source.
5. Locate filter as close as possible to a floor or laundry tub drain and a 120 volt AC electrical outlet.
6. Filters should be located before the water heater on the supply line. If closer than three (3) metres [10 feet], install a check valve in accordance with local plumbing codes.
7. Do NOT install a filter in a location where freezing temperatures occur. Freezing may cause permanent damage to this type of equipment and will void the factory warranty. Freezing could also result in flooding and / or property loss and damage.
8. Allow sufficient space around the unit for easy servicing.
9. Keep the filter out of direct sunlight.

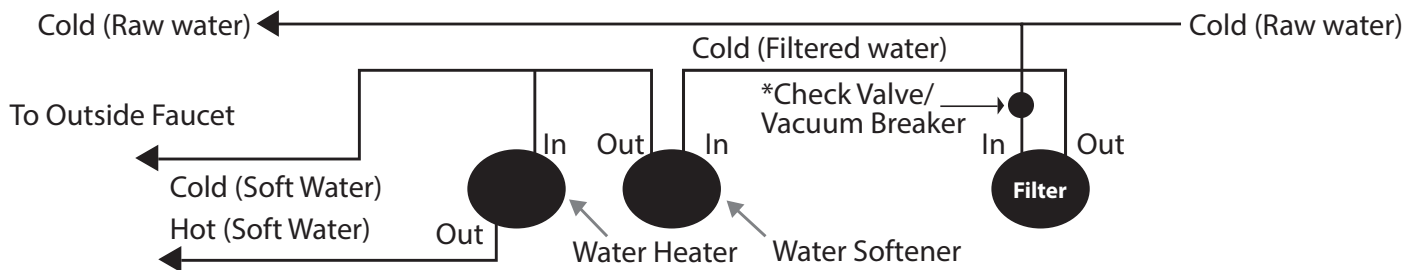

***NOTE**

Check local plumbing codes requirements for use of check valve(s), back-flow prevention, or vacuum breakers. Canature is not liable for any non-compliance with local requirements.

PLANNING YOUR INSTALLATION (CONTINUED)

WATER FILTER INSTALLATION

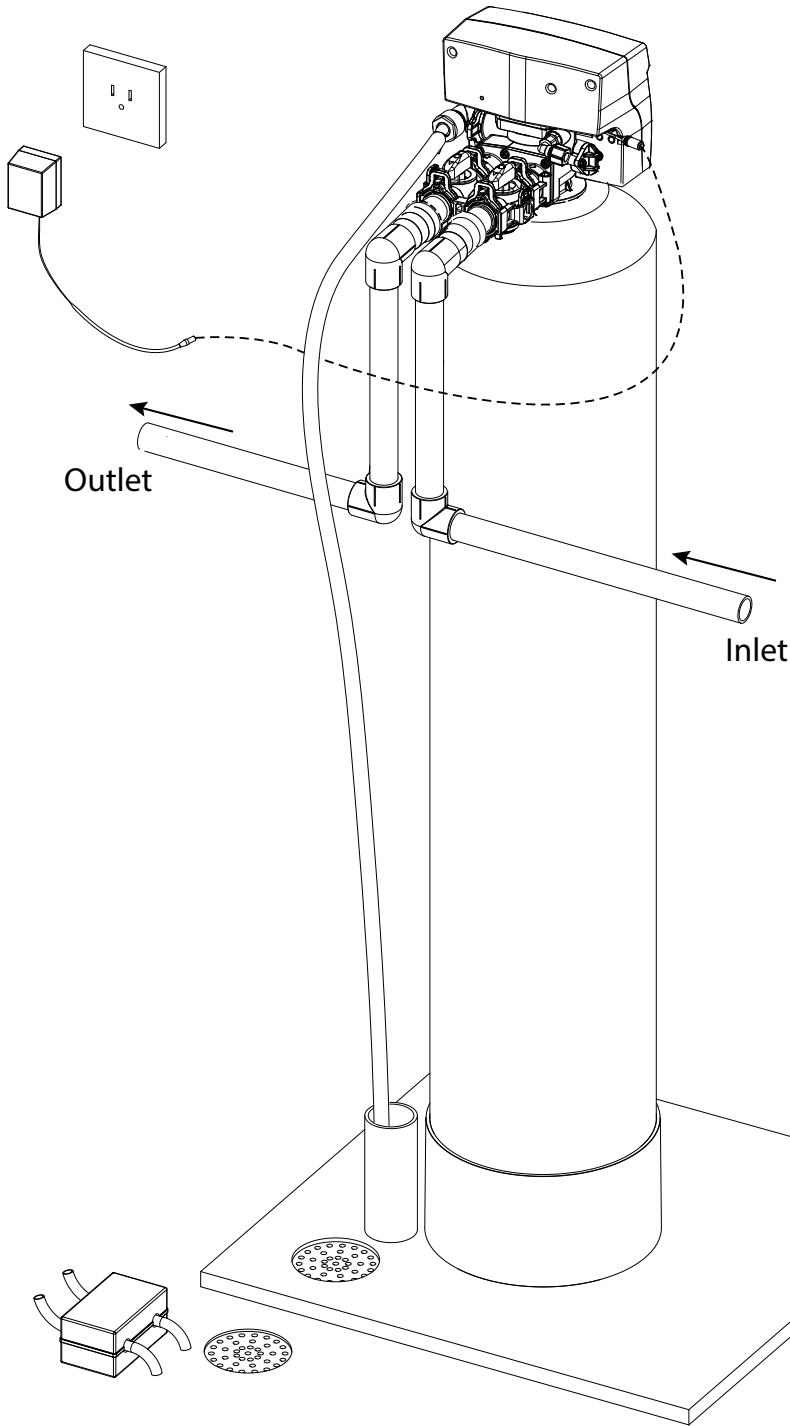

GREENSAND INSTALLATION WITH POTASSIUM PERMANGANATE FEEDER

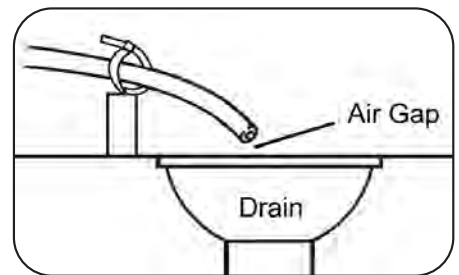
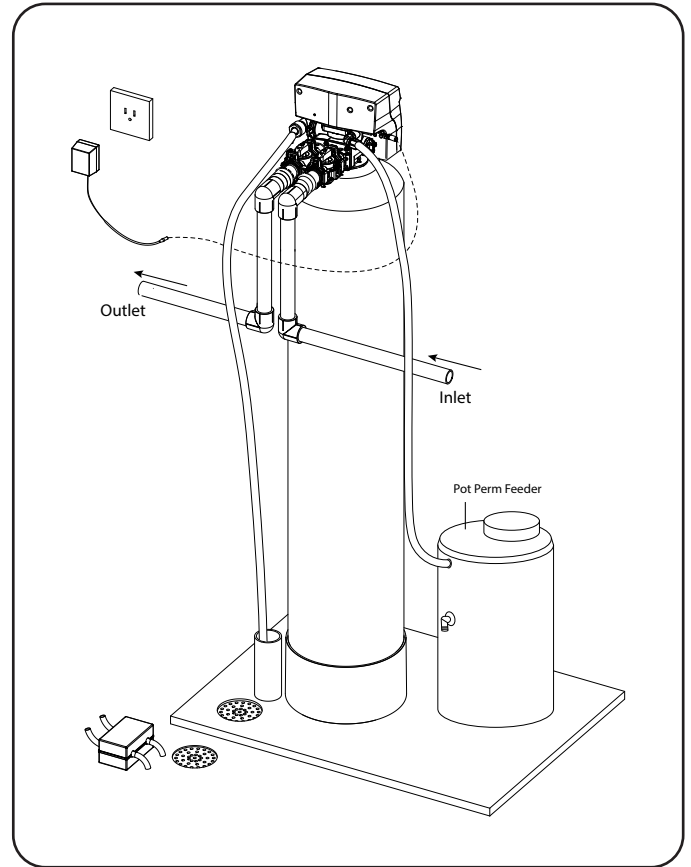

INSTALLATION STEPS

TO BEGIN YOUR INSTALLATION:

1. Make sure the bypass is attached securely to the control valve.
2. Apply thread tape to threaded connections elbow plumbing adaptors
3. Apply the supplied lubricant (#92360) to the O-rings of the fittings.
4. Connect the supplied elbow plumbing adaptors to the bypass with red clips.
5. Connect the inlet and outlet of the water filter to the plumbing of the house.

NOTICE

Any solder joints near the valve must be done before connecting any piping to the valve. Failure to do this could cause damage to the valve.

NOTICE

Do NOT use pipe thread compound as it may attack the material in the valve body.

NOTICE

Failure to leave enough distance could cause damage to the valve. Always leave at least 6" [152 mm] between the valve and joints when soldering pipes that are connected to the valve.

6. For the drain line connection; attach a 1/2" [12.7 mm] Inside Diameter (ID), 5/8" [15.875 mm] Outside Diameter (OD) drain hose to the drain line fitting.
 - a. Run the drain line to a floor or laundry drain.
 - b. Complete any necessary plumbing to maintain a proper air gap.

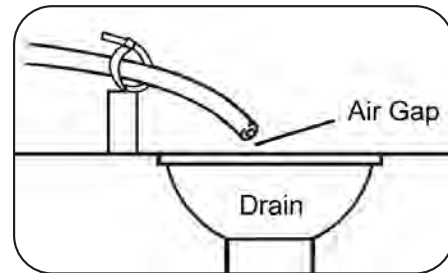

NOTE

The waste connections or drain outlet shall be designed and constructed to provide for connection to the sanitary waste system through an air-gap of 2 pipe diameters or 1" [25.4 mm] whichever is larger.



CAUTION

Never insert drain line directly into a drain, sewer line, or trap. Always allow an air-gap between the drain line and the wastewater to prevent the possibility of sewage being back-siphoned into the filter.

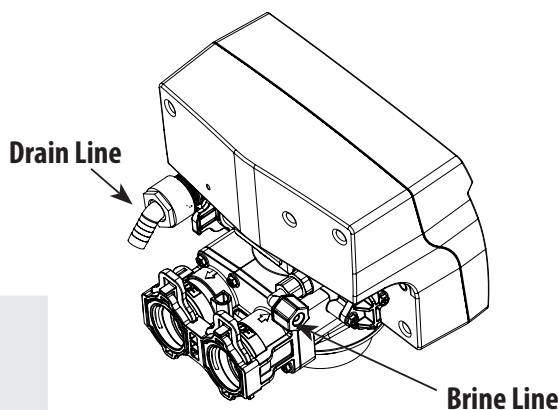

INSTALLATION STEPS (CONTINUED)

7. Using the included Allen key, place the unit in the bypass position.
 - a. Slowly turn the main water supply ON.
 - b. At the nearest cold treated water tap, remove the tap screen, OPEN the tap and let water run a few minutes or until the system is free of any air or foreign material resulting from the plumbing work.

MANUAL WATER BYPASS

In case of an emergency, or to perform filter maintenance, you can isolate your water filter from the water supply using the bypass valve located at the back of the control.

In normal operation the bypass is OPEN with the ON/OFF knobs in line with the INLET and OUTLET pipes, i.e., the black marks in the vertical position. See SERVICE below.

To isolate the filter, simply rotate the knobs as indicated to the CLOSE position until they lock. You can continue to use your water related fixtures as the water supply is bypassing the filter. However, the water you use will be untreated.

To resume treated service, OPEN the bypass valve by rotating the knobs back to the SERVICE position.

NOTE

If the tap has a screen, it should be removed to allow debris to flush out of the plumbing.

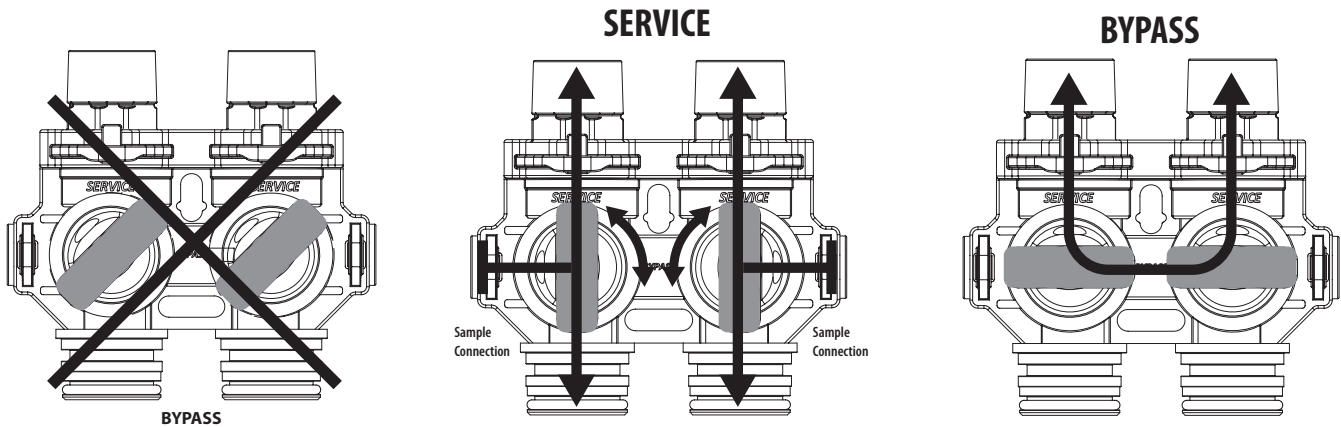

NOTE

Please make sure bypass knobs are completely open otherwise the untreated water may enter through the valve.

9. Make sure there are no leaks in the plumbing system before proceeding. Shut the water tap OFF when the water runs clean.

GREENSAND STARTUP

1. Remove the locking clip on the brine fitting & insert one end of the 3/8" tubing (included) into this fitting all the way until the tube can go in no further. Replace the locking clip.
2. Remove the top lid of the chemical tank. The other end of the tubing goes through the small hole near the top of the chemical tank. Bring the end of the 3/8" tubing into the brine well and make the connection with the compression fitting on the safety float.
3. The barbed elbow near the middle of the chemical tank is for a "gravity" overflow line in case of a malfunction resulting in a tank overflow. This must be run to drain. It uses the same size tubing as the drain line. **WARNING : DO NOT TEE THESE TWO TOGETHER.**

Remove the elastic band from the float assembly inside the chemical tank. DO NOT REMOVE WHITE FELT PAD FROM INSIDE THE CHEMICAL TANK.

4. **Open the bypass inlet very slowly** until there is a steady stream of water at the drain. Opening the bypass inlet too quickly could result in resin being expelled from the unit and into the plumbing lines. With the valve in the backwash position the unit will purge air from the system, sending it to the drain. This may take longer than the programmed backwash cycle time, so unplug the power so that the valve will remain in the backwash position.
5. With the bypass inlet now fully open, let the system run until all the air is purged and there is a steady stream of water at the drain.
6. Reconnect the power, press button two (2) to advance to the refill position and allow the unit to refill to 1" [25.4 mm] above the grid board – this may require manually advancing the unit through its cycles more than once. Alternatively, you can press and hold button 2 (two) to advance to the service position and manually add the required amount of water as described in the next step.

ADD THE CHEMICAL (POT-PERM): The bottom of the chemical tank has a felt pad. **DO NOT REMOVE THIS FELT PAD.** With a bucket or hose, pour approximately 1 gallon of water into the chemical tank. The exact level is not critical, but be careful not to overflow the tank.



Potassium permanganate is a Class C - Oxidizing Material, Class E - Corrosive Material

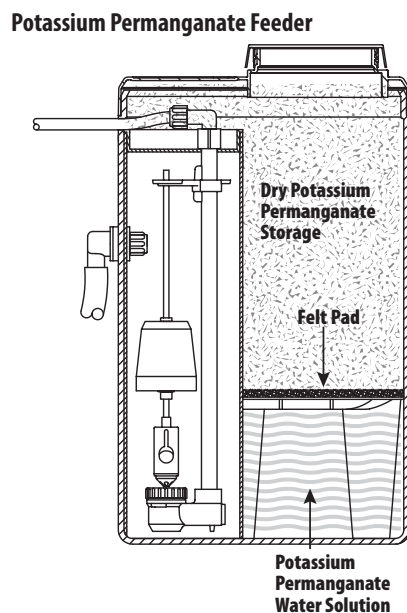

CAUTION

Before adding POT PERM, please check safety instructions included with the POT-PERM jug and label. Pour the entire 5 lb jug of POT PERM into the chemical tank (included with model CGFE948). The powder stays above the felt pad while the water/Pot Perm solution stays below it. Typically, five pounds of POT PERM should last three to four months or more before refilling with POT PERM powder is required.

7. With the bypass inlet now fully open, let the system run until all the air is purged and there is a steady stream of water at the drain.
8. Slowly open the bypass OUTLET knob until fully open.

NOTE

Your unit is not yet ready for service until you complete manual regeneration

UNDERSTAND THE SCREEN & KEYPAD CONFIGURATION

The control valve is controlled with simple, user-friendly electronics, displayed on an LCD screen.

Connect the Transformer



Connect the transformer to the unit by plugging the 12 volt transformer into a 120 VAC 60 Hz outlet.

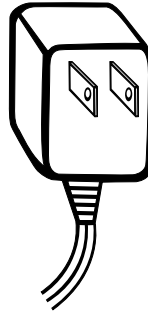
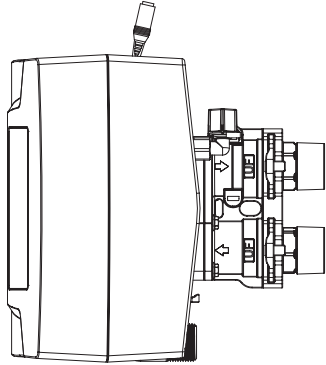

WARNING

if your power supply is subject to surges or frequent outages, surge protection is recommended to protect the electronics in this product.

When the power is connected, the screen will show the following information:

Key Pad Configuration – the terminology used on the control valve label may vary by model. For the purpose of programming, this manual will use numbers associated with each button position as shown below:

- 1** This function is to enter the basic set up information required at the time of installation.
- 3** This function is to initiate an immediate or delayed manual regeneration.
- 2/4** Increase or decrease the value of the settings while in the programming mode.

1

3

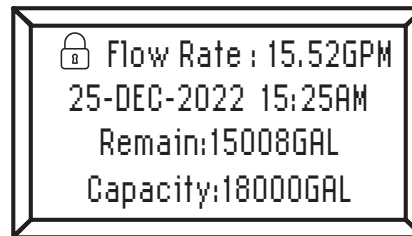

2

4



MANDATORY

Do NOT use an outlet that is controlled by a light switch.

START-UP INSTRUCTIONS

Now that your water conditioner is plumbed into position it is time to start up and program the unit.

STEP 1. PURGE AIR FROM THE UNIT

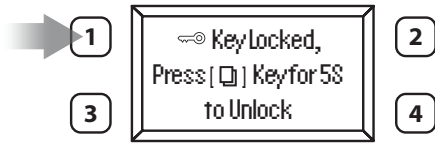

1. Press and hold **button one (1)**, the display will read **"PRESS [] 5 Seconds to Unlock"**. After 5 seconds, the display will keep confirming unlock.

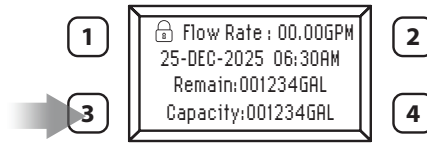

2. Press and hold **button three (3)** to start Manual Regeneration process.
3. Press and hold any button to advance to Backwash.

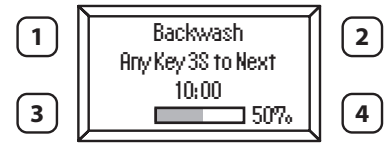

4. The display will indicate the time remaining. **ALLOW TO FINISH FULL CYCLE.**

5. **Open the bypass inlet very slowly** until there is a steady stream of water at the drain. Opening the bypass inlet too quickly could result in resin being expelled from the unit and into the plumbing lines. With the valve in the backwash position the unit will purge air from the system, sending it to the drain. This may take longer than the programmed backwash cycle time, so unplug the power so that the valve will remain in the backwash position.
6. With the bypass inlet now fully open, let the system run until all the air is purged and there is a steady stream of water at the drain.
7. Reconnect the power, press and hold any button to advance to the refill position and allow the unit to refill to 1" [25.4 mm] above the grid board or 3" [76.2 mm] of water in cabinet models – this may require manually advancing the unit through its cycles more than once. Alternatively, you can press and hold any button to advance to the service position and manually add the required amount of water as described in step 1.
8. Allow the unit to return to the SERVICE position.
9. Slowly open the bypass OUTLET knob until fully open.

NOTE

If severe loss in water pressure is observed when the conditioner unit is initially placed in service, the conditioner tank may have been laid on its side during transit. If this occurs, backwash the conditioner to 'reclassify' the media.



MANDATORY

Be sure to open the bypass inlet very slowly. Do NOT FULLY open the bypass inlet until there is a steady stream of water at the drain as this will result in media being expelled from the unit

START-UP INSTRUCTIONS (CONTINUED)

STEP 3. HOW TO SET DATE AND TIME, MANUAL REGENERATION, DEALER INFO

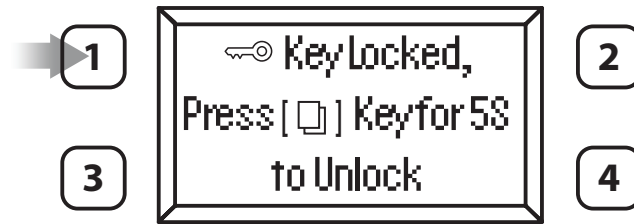

1. Press and hold **button one (1)**, the display will read "PRESS [] 5 Seconds to Unlock".
2. After 5 seconds, the display will beep confirming unlock.
3. Press **button one (1)** [] to enter user programming.

Date & Time

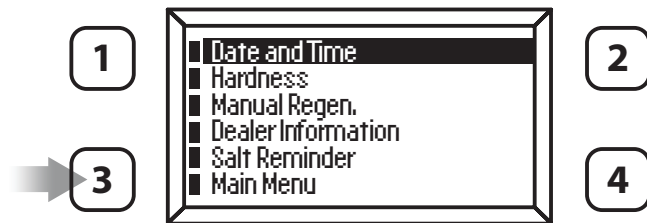

1. Press **button three (3)** to select Date and Time.

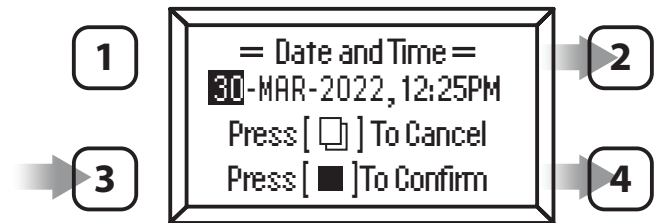

2. Press **buttons two (2)** or **four (4)** to adjust Date and Time. Press **button three (3)** to Confirm.

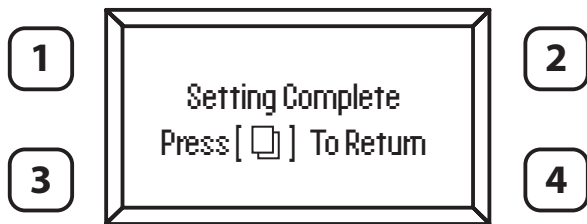

3. Setting complete.

DATE AND TIME

Time of day is for normal operation of system and the scheduling of the regeneration time. The date is used in a diagnostic function to track the last time the system regenerated.

OTHER MAIN MENU FEATURES

To Initiate a Manual Regeneration

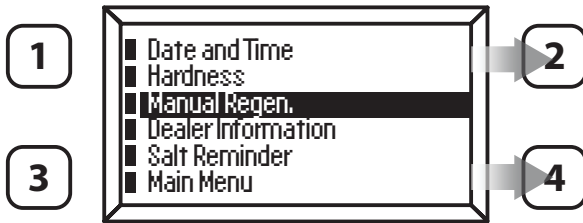

1. Press **buttons two (2) or four (4)** to select Manual Regen.
Press **button three (3)** to Confirm.

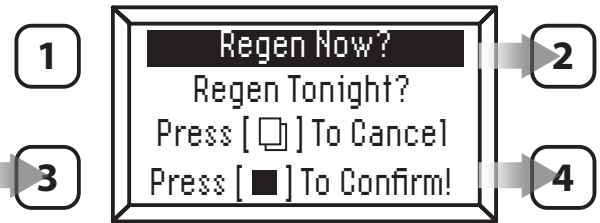

2. Press **buttons two (2) or four (4)** to select Regen Now or Regen Tonight.
Press **button three (3)** to Confirm.

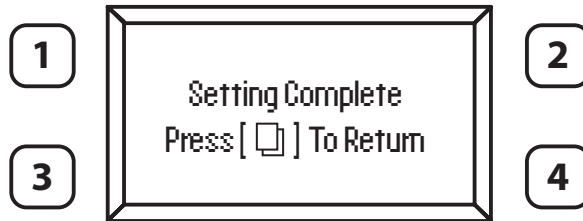

3. Setting complete.

Dealer Info

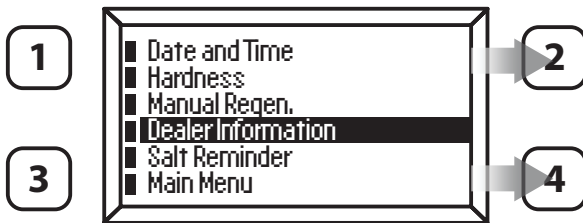

1. Press **buttons two (2) or four (4)** to select Dealer Information.
Press **button three (3)** to Confirm.

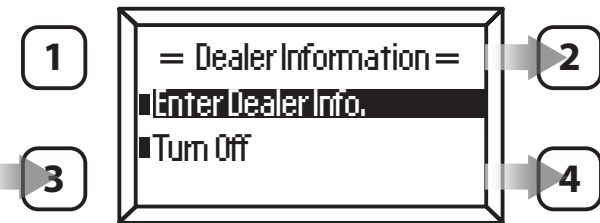

2. Press **buttons two (2) or four (4)** to select.
Press **button three (3)** to Confirm.



3. Press **buttons two (2) or four (4)** to select desired Letters or Numbers.
Press **button three (3)** to Confirm.

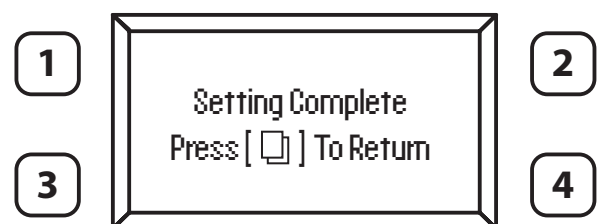

4. Setting complete.

PLUMBING SYSTEM CLEAN UP

The following procedures are guidelines only but have proven successful in most instances. Under no circumstances should any procedure outlined below be followed if contrary to any other household appliances manufacturer's instruction(s). Should there be any questions concerning the advisability of performing a procedure, it is strongly recommended that the dealer be consulted prior to performing the procedure. Canature is not liable for any damages that result of failing to follow the household appliance manufacturer's instructions and/or any issues that arise from following those instructions.

WATER HEATER

If the water heater has been exposed to both iron and hardness for a long period of time, replacement of the heater tank maybe the only practical solution to prevent continued staining originating from this source. After completing the installation of the filter, clean the water heater by following these instructions;

1. Turn the energy supply to the water heater OFF and shut the heater inlet water valve OFF.
2. Drain hot water tank completely. OPEN the Inlet Water Valve allowing the heater tank to be refilled with iron free water. Continue flushing until clear water runs to the drain.
3. If, after 30 minutes flushing, the water does NOT clear, terminate flushing operation.
4. REFILL hot water heater with water and pour approximately .5 gal or [.19 Litres] of household bleach into the top of the heater tank. Allow bleach solution to stand in tank for thirty (30) minutes. Flush tank.
5. Turn the energy supply back ON.

DISHWASHER

Dishwashers may have scale buildup due to prolonged exposure to hard water effecting the factory rated performance. Consult the owner's handbook and follow the manufacturer's instructions.

TOILET FLUSH TANKS

To clean up toilet flush tanks:

1. Pour 4 to 6 fluid ounces [120-175 millilitres] of resin mineral cleaner, Pro-Rust Out or any other suitable cleaner that contains a mild acid, such as CLR, into flush tanks and bowls, and let stand for one (1) hour.
2. When installation is completed, flush toilets several times with conditioned water.
3. If stains or deposits return, check that the lines are connected to treated water.

MAINTENANCE INSTRUCTIONS

Your chem free iron filter requires some minor maintenance to ensure optimum performance and years of trouble-free clean water. The following steps should be performed once or twice a year (more often under harsh conditions):

1. Verify the pumping rate of the system - do not refer to a pumping curve for this data. Follow the instructions found on page 7. If the measured pumping rate is less than the backwash rate of the filter, see page 39, Trouble Shooting.
2. Have your water tested - for pH, iron and manganese on both the treated and raw water to ensure your water conditions haven't changed.
3. Inspect the Control Valve and the piping between the iron filter and the pressure tank to ensure they are not plugged with raw iron. If the line becomes plugged, the flow of water to the home will be reduced. This will result in a reduction of water available for backwashing the unit which will inhibit operation of the system.
4. Air-to-water pressure tank - periodically drain and flush your tank to prevent a build-up of precipitated iron from forming in the bottom of the tank.
5. Bladder tank - periodically check that the bladder air pressure remains at 2 psi lower than the cut-in pressure of your pump.
6. For applications with low pH, manganese or hydrogen sulfide, consult your local dealer for specific instructions to maintain the efficiency and operation of your filter.
7. Periodic cleaning of the air vent assembly with mild acid or vinegar will ensure that it continues to vent excess air properly.
8. The filter tank can be cleaned with a mild soap solution.
9. Never subject the unit to freezing

MAINTENANCE INSTRUCTIONS (CONTINUED)

CARE OF YOUR FILTER

To retain the attractive appearance of your new water filter, clean occasionally with a mild soap solution. Do not use abrasive cleaners, ammonia or solvents. Never subject your filter to freezing or to temperatures above 43°C (110°F).

SERVICING COMPONENTS

- The seals and spacers along with the piston assembly should be inspected/cleaned or replaced annually or as required depending on the inlet water quality and water usage. See **Inspection and Replacement of Piston Assembly and Seal and Spacer Kit**.
- The injectors should be cleaned/inspected or replaced annually or as required depending on the water quality and use. See **Clean Injector Assembly**.
- Your inlet water quality and water consumption will determine how often the media should be replenished or replaced. Check with your water treatment expert for the media bed change frequency.
- Maintenance materials – Please see **Common Spare Parts**.
- Type M units only. The pH of your Raw water and treated water should be monitored at least monthly for the first year to determine when additional media will be required. Once the pH is equal or below 7.0 additional media will be needed to refresh the media bed please order item **95442 5 lb Jar of pH Adder**.
- Check and clean the cross pipes and air tank annually.

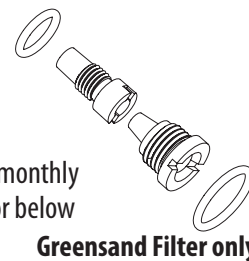

Maintenance Kit

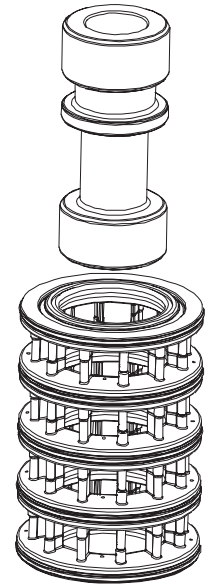

REPLACING MEDIA BED

TO - under normal operating conditions the effective life of the filter media is approximately one to three years depending on the water quality, after which, taste and odor problems may return. When this happens contact your dealer for a replacement media bed.

NU - the media bed in a neutralizing filter is slowly dissolved and has to be replaced. The frequency of replacement varies, depending on water quality - consult your dealer to determine the expected life of your media bed.

Greensand/BIRM- Depending on the raw water iron content.

MM / NextSand - under normal operating conditions, the media should never need to be replaced. If you experience pressure loss and cannot correct it with a manual regeneration, your media bed may need replacing - contact your dealer.

TO DETERMINE THE FREQUENCY OF REGENERATION OF GREENSAND FILTERS, USE THIS PROCEDURE:

IRON CONTENT IN THE FEED WATER:

ppm of capacity between regenerations (see Feed Water Parameters - Page 7)

- ÷ ppm of iron in the water sample*
- = number of gallons supplied between regenerations
- reserve capacity (number of people x 75 gallons)

Example - Using 5600 SXTM-948IF + 1 Feeder

$$\begin{array}{r}
 6000 \text{ ppm between regenerations} \\
 \div \quad 8 \text{ ppm of compensated iron [To be entered by the user]} \\
 \hline
 = \quad 750 \text{ gallons between regenerations [See step \#5 of "User Programming"]} \\
 - \quad 375 \text{ gallons reserve capacity (5 people x 75 gallons)} \\
 \hline
 = \quad 375 \text{ GALLONS - BETWEEN REGENERATIONS [Calculated by valve]}
 \end{array}$$

* 1 ppm of manganese = 2 ppm of iron; 1 ppm of hydrogen sulfide = 3 ppm of iron

$$\begin{array}{r}
 6000 \text{ ppm between regenerations} \\
 \div \quad 8 \text{ ppm of compensated iron [To be entered by the user]} \\
 \hline
 = \quad 750 \text{ gallons between regenerations [See step \#5 of "User Programming"]} \\
 - \quad 375 \text{ gallons reserve capacity (5 people x 75 gallons)} \\
 \hline
 = \quad 375 \text{ GALLONS - BETWEEN REGENERATIONS [Calculated by valve]}
 \end{array}$$

DAYS:

- Total amount of iron to be removed between regenerations -
- ÷ ppm of iron to be removed per day
- = NUMBER OF DAYS BETWEEN REGENERATIONS

Example

$$\begin{array}{r}
 5 \text{ people in the household} \\
 \times \quad 75 \text{ gallons of filtered water per person} \\
 \hline
 = \quad 375 \text{ gallons of filtered per day} \\
 \times \quad 8 \text{ ppm of compensated iron} \\
 \hline
 = \quad 3000 \text{ PPM OF IRON TO BE REMOVED PER DAY}
 \end{array}$$

Using 5600 SXTM-948IF + 1 Feeder

$$\begin{array}{r}
 6000 \text{ ppm capacity} \\
 \div \quad 3000 \text{ ppm to be removed per day} \\
 \hline
 = \quad 2^{**} \text{ DAYS BETWEEN REGENERATIONS}
 \end{array}$$

**Maximum number of days between regenerations should be 12.

Specifications

Media (CF)	Iron Capacity (ppm)
0.75	4500
1	6000
1.5	9000
2	12000
3	18,000

SERVICING YOUR CONTROL VALVE

BEFORE SERVICING, YOU WILL NEED TO:

1. Shut the water supply to the conditioner OFF, put the conditioner into the BYPASS position.
2. Relieve water pressure in the conditioner by stepping the control into the backwash momentarily.
3. Return the control to the SERVICE position.
4. Unplug the electrical cord.
5. Disconnect the drain line connection.

Always follow these steps prior to servicing the valve.

NOTICE

Do NOT use petroleum-based grease products during replacement and assembly.

POWERHEAD REMOVAL

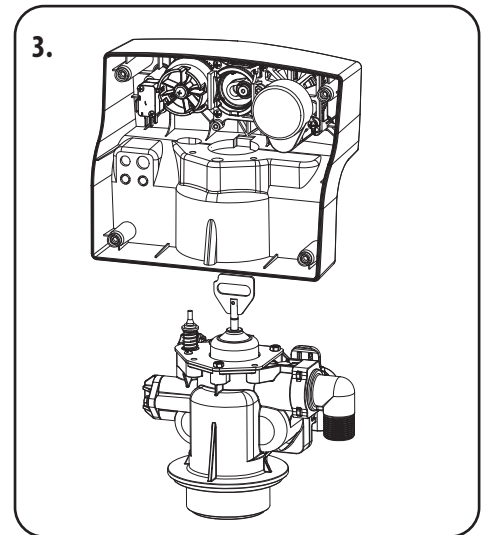
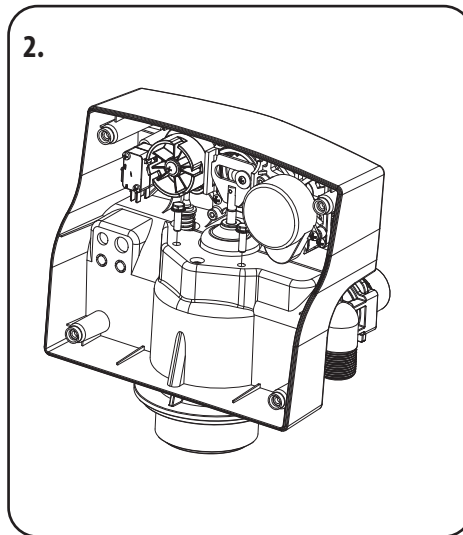
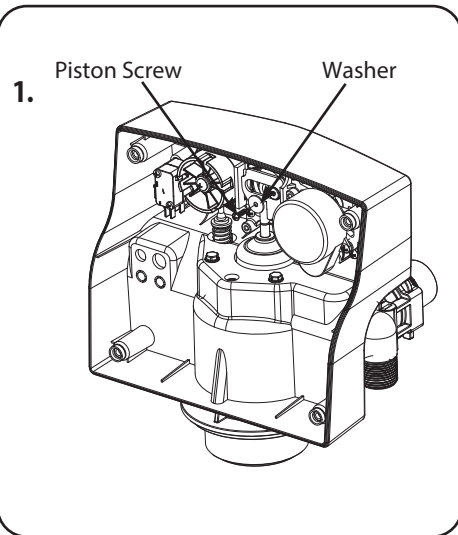

To remove the powerhead:

1. Remove screw & washer from piston rod link.

2. Remove two (2) bolts securing powerhead to body.

3. Remove powerhead from body.

INSPECTION & REPLACEMENT OF PISTON ASSEMBLY AND SEAL & SPACER KIT

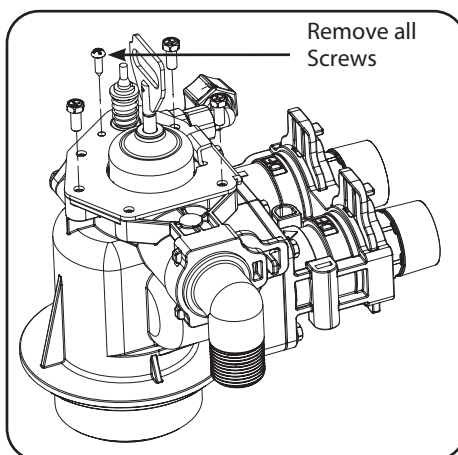

1. Follow steps 1 to 3 of Powerhead Removal above.

2. Remove four (4) screws from the plate on the valve body.

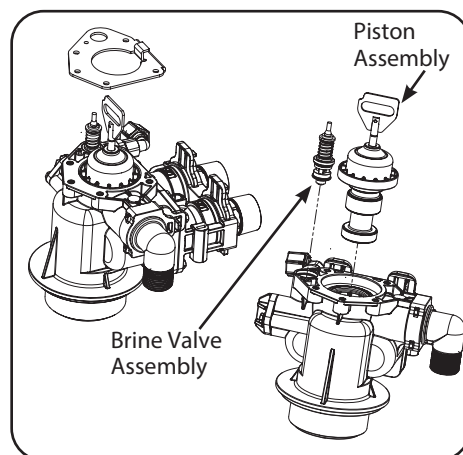

3. Remove the plate from the valve body and pull the piston assembly from the valve. The brine valve assembly can also be removed in this stage.

4. If only lubricating, remove the piston assembly, grease it with silicone lubricant (Part #92360) and put back in.

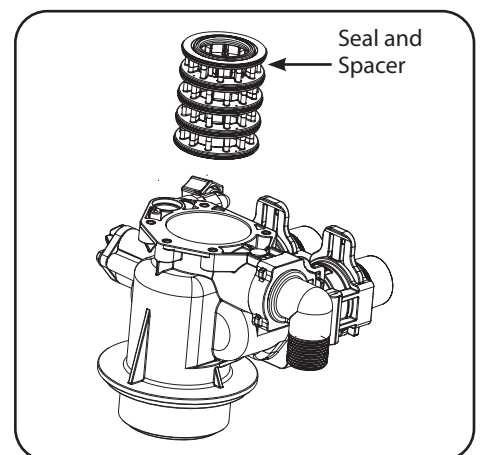

5. Replace seal and spacer set as shown. Place spacer in then a seal and repeat until finishing with a seal.

6. Lubricate the piston assembly with silicone lubricant (Part #92360) and then replace the Piston Assembly.

SERVICING YOUR CONTROL VALVE (CONTINUED)

INSPECTION & REPLACEMENT OF INJECTORS (FOR GREENSAND MODELS ONLY)

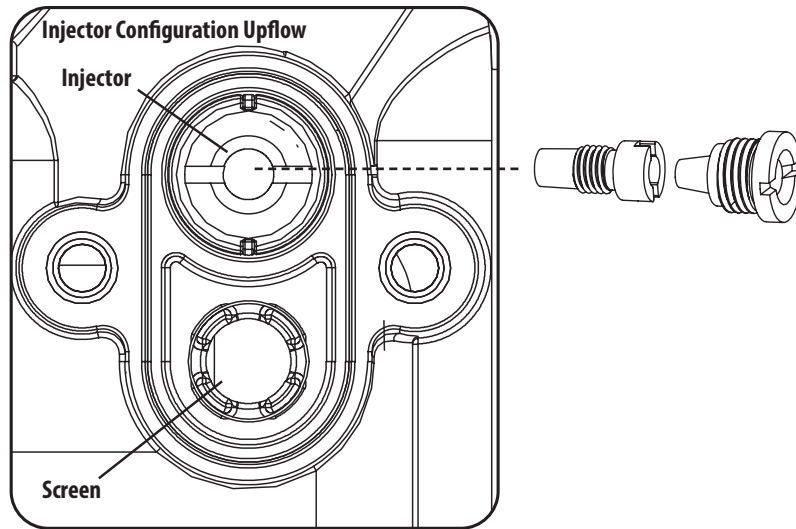

TROUBLESHOOTING GUIDE

NOTE

Before attempting any troubleshooting, be sure to test the water. The tests should include;

1. Raw water
2. Hot treated water
3. Cold treated water.

Problem	Cause	Correction
1. Filter bleeds taste and odor or sediment	<ul style="list-style-type: none"> A. Bypass valve is open B. Electrical service to unit has been interrupted C. Defective or stripped media bed D. Quality of water has worsened E. Filter capacity too small F. Filter not backwashing enough G. Excessive water usage - calendar clock models 	<ul style="list-style-type: none"> A. Close bypass valve B. Assure permanent electrical service (check fuse, plug or switch) C. Replace media D. Have water sample analyzed to determine any change E. Replace with larger unit or add another filter F. Be sure flow control is not clogged or drain line restricted. Be sure water pressure has not dropped and that pump has sufficient capacity G. Increase frequency of regeneration. Make sure there are no leaks in toilets or sinks
2. Filter fails to regenerate	<ul style="list-style-type: none"> A. Electrical service to unit has been interrupted B. Timer is defective C. Power failure D. Timer motor does not run 	<ul style="list-style-type: none"> A. Assure permanent electrical service (check fuse, plug or switch) B. Replace timer C. Reset time of day D. Replace defective motor
3. Filter regenerates every day	<ul style="list-style-type: none"> A. Faulty gear train 	<ul style="list-style-type: none"> A. Check unit sizing and programming
4. Loss of water pressure	<ul style="list-style-type: none"> A. Iron or turbidity build-up in filter B. Filter not regenerating often enough C. Not enough water volume or pressure to backwash properly 	<ul style="list-style-type: none"> A. Clean control and treat bed with Iron Out. Increase frequency of regeneration B. Increase frequency of regeneration C. Correct water supply problem
5. Loss of media through drain line	<ul style="list-style-type: none"> A. Air in water system B. Backwash rate too fast 	<ul style="list-style-type: none"> A. Assure that well system has proper air eliminator control. Check for dry well condition B. Check drain flow control for proper flow rates
6. Drain flows continuously	<ul style="list-style-type: none"> A. Foreign material in control B. Timer motor stopped or jammed 	<ul style="list-style-type: none"> A. Remove piston assembly and inspect bore. Remove foreign material and check control in various regeneration positions B. Replace timer motor

COMMON SPARE PARTS

Part Number	Description
60090026	Elbow, Inlet/Outlet, 1" NPT Comes with O-Ring
60090027	Straight, Inlet/Outlet, 1" NPT Comes with O-ring
60090040	Elbow, Drain line, 1/2" NPT Comes with O-Ring
60090029	Elbow, Drain line, 3/4" NPT Comes with O-Ring
60090030	Elbow, Drain line, 1" NPT Comes with O-Ring
60090028	Drain Line Hose Barb
60010227	Drain Line Red Clip
92387	Large Red Bypass Clip
60010069	Brine Line Red Clip
60010006	Bypass tool
60010052	Transformer 12 volt
60010382	Problem water injector kit
92360	100% silicone-based lubricant
99003	Media Funnel
92383	Downflow Piston Assembly
60010417	Brine Valve
92382	Seal & Spacer Kit
60010036	Injector Set #2 Grey PVC

Page intentionally blank

WARRANTY

89DF Residential Water Filter

NOTICE: THIS MANUAL CONTAINS A LIMITED WARRANTY. BY INSTALLING AND/OR USING THIS PRODUCT, YOU WAIVE CERTAIN LEGAL RIGHTS INCLUDING THE RIGHT TO SUE OR CLAIM COMPENSATION IN THE EVENT OF PROPERTY DAMAGE, INJURY AND/OR DEATH.

Products manufactured and assembled by Canature WaterGroup™ are warranted to do the work for which they are intended where properly installed, operated and maintained. Canature WaterGroup™ warrants each new residential water filter to be free from defects in materials and workmanship subject to the qualifications or exclusions below.

Residential Systems are defined by pressure tank size and / or the amount of resin or filter media contained in the tank. Residential systems use up to 13" [330 mm] diameter tanks and can contain up to 3.0 cubic feet [28.3 L] of resin or filter media.

Warranty on Control Valve and Parts:

Canature WaterGroup™ will replace or repair any part (except for Wear and Tear Items – Media, Piston, Seals and Brine Valve) which fails within seven (7) years from date of manufacture, as indicated by the serial number, provided the failure is due to a defect in material or workmanship. The only exception from the date of manufacture shall be proof of purchase or installation is provided and then the warranty period shall be from the date thereof.

Warranty on Mineral Tanks and Brine Tanks:

Canature WaterGroup™ will provide a replacement mineral tank or brine tank to any original equipment purchaser in possession of a tank that fails within the lifetime of the original owner, provided the failure is due to a defect in material or workmanship and that the water filter or filter is at all times operated in accordance with specifications provided in the Owner's Manual and not subject to freezing or vacuum.

Exclusions:

Damage to any part of this water filter or filter as a result of misuse, misapplication, neglect, alteration, accident, installation or operation contrary to our printed instructions, damage to ion exchange resin and seals caused by chlorine / chloramines in the water supply, damage to internal pistons and seals caused by wear and tear from iron, manganese, sediment and or silt, or damage caused by any force of nature is not covered in this warranty. At our sole discretion, we will repair or replace defective parts if our warranty department determines it to be defective under the terms of this warranty. Canature WaterGroup™ assumes no responsibility for consequential damage, labor or expense incurred as a result of a defect or failure. Media and Resin coverage is limited to the warranty provided by the original manufacturer.

As a manufacturer, we do not know the characteristics of your water supply. The quality of water supplies may vary seasonably or over a period of time. Your water usage may vary as well. Water characteristics can also change if the appliance is moved to a new location. For these reasons, we assume no liability for the determination of the proper equipment necessary to meet your requirements, and we do not authorize others to assume such obligation for us. Further, we assume no liability and extend no warranties, express or implied, for the use of this product with a non-potable water source or a water source which does not meet the conditions for use as described in the Owners Guide.

CANATURE WATERGROUP'S™ OBLIGATIONS UNDER THIS WARRANTY ARE LIMITED TO THE REPAIR OR REPLACEMENT OF THE FAILED PARTS OF THE WATER SOFTENING SYSTEM AND WE ASSUME NO LIABILITY WHATSOEVER FOR DIRECT, INDIRECT, INCIDENTAL, CONSEQUENTIAL, SPECIAL, GENERAL OR OTHER DAMAGES.

Return of Goods:

An authorization number must be obtained before returning any merchandise. NOTE: All material returned to Canature Watergroup must be returned freight prepaid. Upon inspection, if our warranty department determines the goods to be defective under the terms of this warranty, the warranty shall be limited to the defective parts to be repaired, replaced, or credited at Canature WaterGroup's discretion. You pay only freight to return defective parts to our factory and local dealer charges, including but not limited to labor charges, travel and transportation expenses, and handling fees.

Some State & Provincial jurisdictions do not allow limitations on how long an implied warranty lasts, so the above limitation may not apply to you. Similarly, some State & Provincial jurisdictions do not allow exclusion of incidental or consequential damages, so the above limitations or exclusions may not apply to you. This warranty gives you specific legal rights, and you may also have other rights, which vary from jurisdiction to jurisdiction. Consult your authorized Dealer for warranty and service information.

28

Toll Free: 1-877-288-9888
www.canaturewg.com

80155332 REV 2 2023-10-11